

## DC MOTOR

60W  
~200W

□90mm

### DIMENSIONS

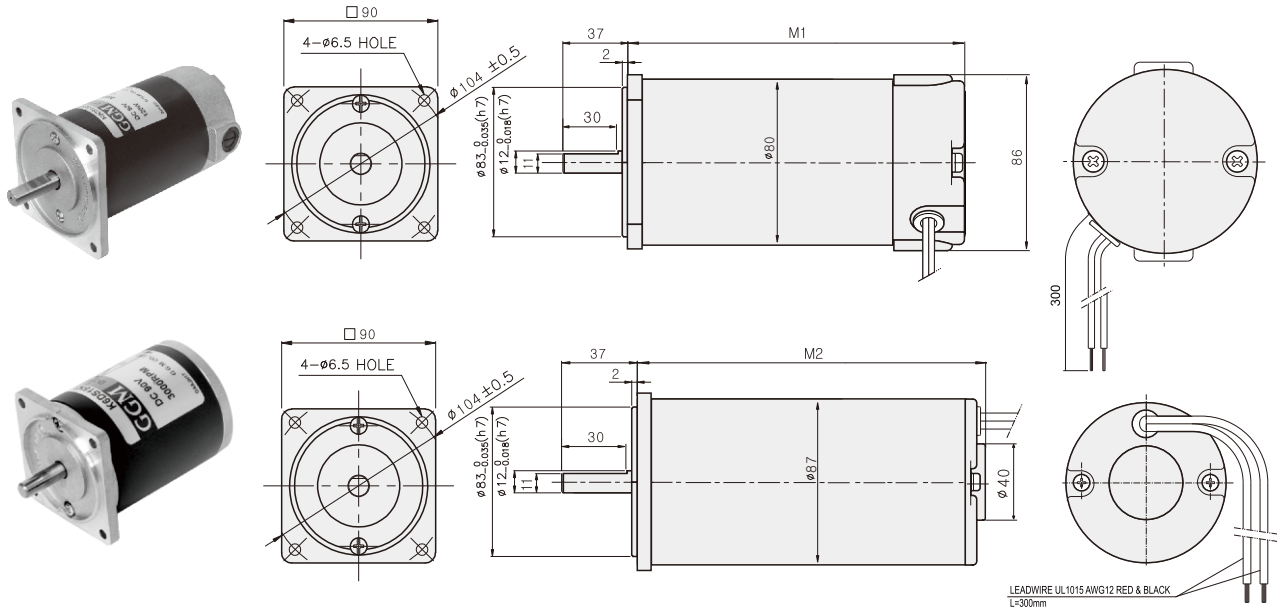

### CONNECTION DIAGRAMS

RED ⊕ CW  
BLACK ⊖ CCW

※ The direction of motor rotation is as viewed from the front shaft end of the motor

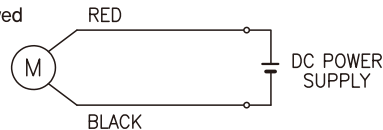

### DIMENSION TABLE

M1	∅	MOTOR	M2	∅	MOTOR
143	80	K9D□60N□ K9D□90N□	170	87	K9D□150N1 K9D□200N1 K9D□200N2
168		K9D□120N□ K9D□150N2 K9D□150N3 K9D□200N3			

### SPECIFICATIONS

Model	Output (W)	Voltage (V)	RATED			Start T. (N·m/kgf·cm)	Starting Current (A)
			Speed (rpm)	Torque (N·m/kgf·cm)	Current (A)		
K9D□60N1	60	12	3000	0.19/1.9	12	1.46/14.6	80
K9D□60N2		24			4.6	2.73/27.3	60
K9D□60N3		90			1.4	2.18/21.8	13
K9D□90N1	90	12	3000	0.3/3	13.4	1.63/16.3	76
K9D□90N2		24			5.9	3/30	67
K9D□90N3		90			1.6	2.3/23	14
K9D□120N1	120	12	3000	0.39/3.9	17.9	1.75/17.5	90
K9D□120N2		24			7.7	3.95/39.5	85
K9D□120N3		90			1.9	4.39/43.9	25
K9D□150N1	150	12	3000	0.49/4.9	21.1	2.22/22.2	111
K9D□150N2		24			9	4.29/42.9	94
K9D□150N3		90			2.5	5/50	30
K9D□200N1	200	12	3000	0.65/6.5	28	1.8/18	89
K9D□200N2		24			12	5.2/52	124
K9D□200N3		90			3.3	5.55/55.5	32

\* □ : SHAFT SHAPE (S : STRAIGHT, P : PINION)

## GEARHEAD

### DIMENSIONS

K9P□B



K9P□BF, BUF

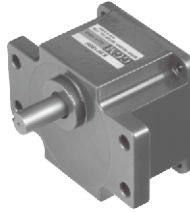

K9P□BU

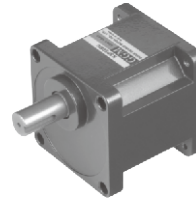

### DECIMAL GEARHEAD

K9P10BX

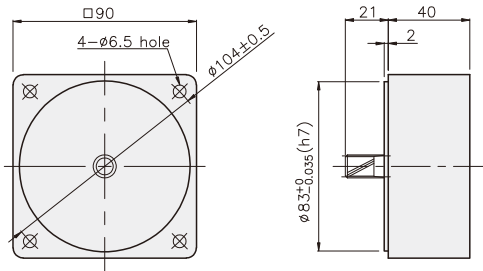

### KEY SPEC

● KEY

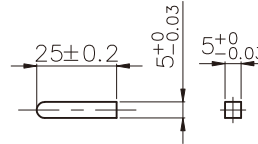

● KEY GROOVE

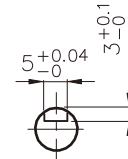

### GEARHEAD

K9P□B

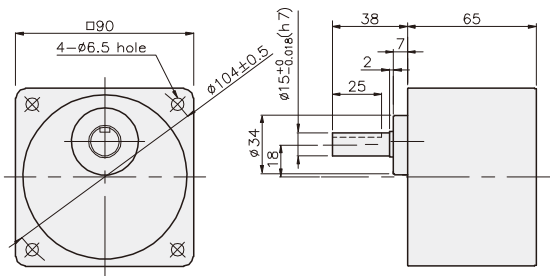

K9P□BF

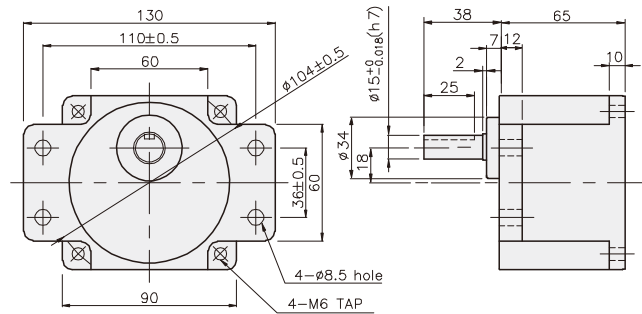

K9P□BU

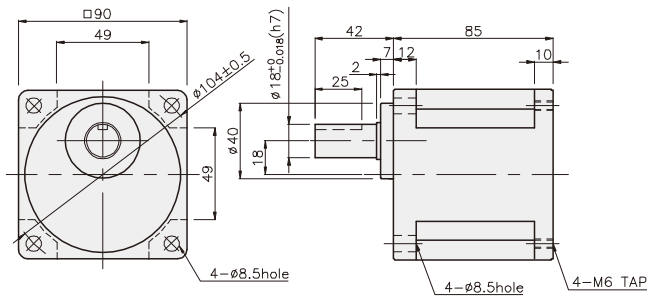

K9P□BUF

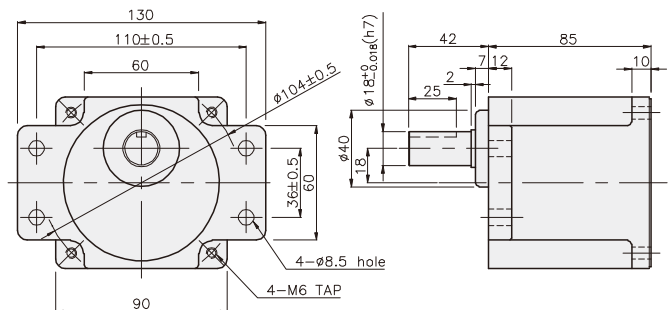

## GEARHEAD

### DIMENSIONS

#### DIMENSION TABLE

PART No	Application Model	Mounting BOLT
01	K9P3~200B	M6 P1,0 X 95
02	K9P10BX	M6 P1,0 X 140

#### WEIGHT

PART	WEIGHT(kg)
K9D□60N□ K9D□90N□	2.21
K9P10BX	0,62
K9P3~10B	1,22
K9P12,5~20B	1,32
K9P25~60B	1,42
K9P75~200B	1,45

#### K9DP□N□ + K9P□B

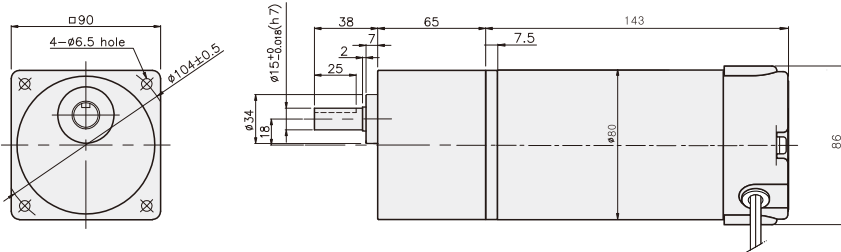

#### DIMENSION TABLE

PART No	Application Model	Mounting BOLT
01	K9P3~200BF	M6 P1,0 X 20
02	K9P10BX	M6 P1,0 X 65

#### WEIGHT

PART	WEIGHT(kg)
K9D□60N□ K9D□90N□	2.21
K9P10BX	0,62
K9P3~10BF	1,22
K9P12,5~20BF	1,30
K9P25~60BF	1,42
K9P75~200BF	1,44

#### K9DP□N□ + K9P□BF

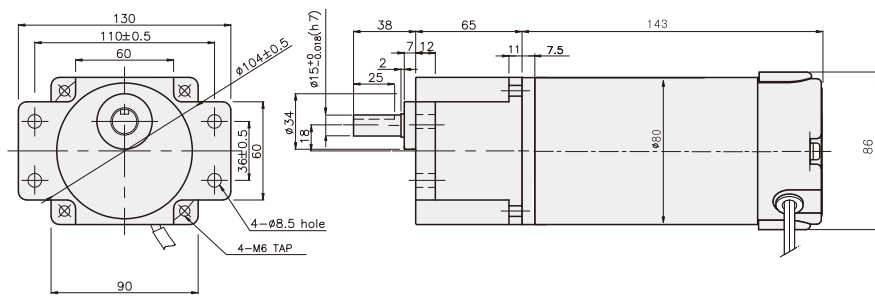

#### DIMENSION TABLE

PART No	Application Model	Mounting BOLT
01	K9P3~200BU	M6 P1,0 X 20
02	K9P10BX	M6 P1,0 X 65

#### WEIGHT

PART	WEIGHT(kg)
K9D□60N□ K9D□90N□	2.21
K9P10BX	0,62
K9P3~10BU	1,44
K9P12,5~20BU	1,55
K9P25~60BU	1,69
K9P75~200BU	1,74

#### K9DP□N□ + K9P□BU

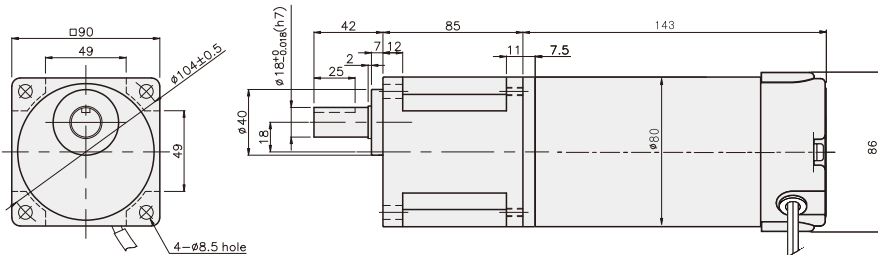

#### DIMENSION TABLE

PART No	Application Model	Mounting BOLT
01	K9P3~200BUF	M6 P1,0 X 20
02	K9P10BX	M6 P1,0 X 65

#### WEIGHT

PART	WEIGHT(kg)
K9D□60N□ K9D□90N□	2.21
K9P10BX	0,62
K9P3~10BUF	1,50
K9P12,5~20BUF	1,62
K9P25~60BUF	1,76
K9P75~200BUF	1,82

#### K9DP□N□ + K9P□BUF

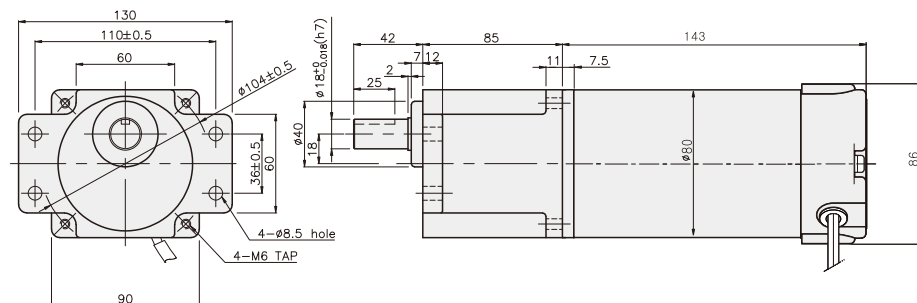

## GEARHEAD

### DIMENSIONS

DIMENSION TABLE

PART No	Application Model	Mounting BOLT
01	K9P3~200BU	M6 P1,0 X 20
02	K9P10BX	M6 P1,0 X 65

WEIGHT

PART	WEIGHT(kg)
K9D□120N□ K9D□150N3	3.20
K9D□200N3	3.30
K9P10BX	0.62
K9P3~10BU	1.44
K9P12,5~20BU	1.55
K9P25~60BU	1.69
K9P75~200BU	1.74

K9DP□N□ + K9P□BU

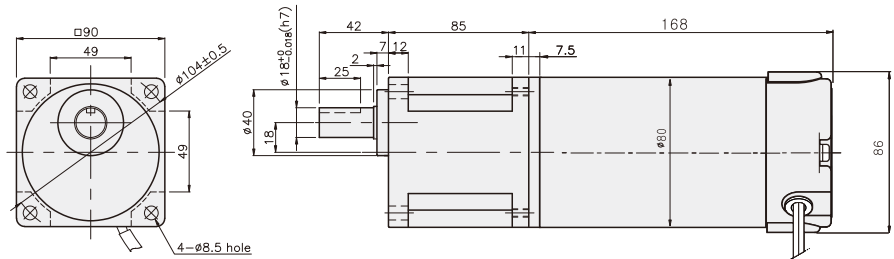

DIMENSION TABLE

PART No	Application Model	Mounting BOLT
01	K9P3~200BUF	M6 P1,0 X 20
02	K9P10BX	M6 P1,0 X 65

WEIGHT

PART	WEIGHT(kg)
K9D□120N□ K9D□150N3	3.20
K9D□200N3	3.30
K9P10BX	0.62
K9P3~10BUF	1.50
K9P12,5~20BUF	1.62
K9P25~60BUF	1.76
K9P75~200BUF	1.82

K9DP□N□ + K9P□BUF

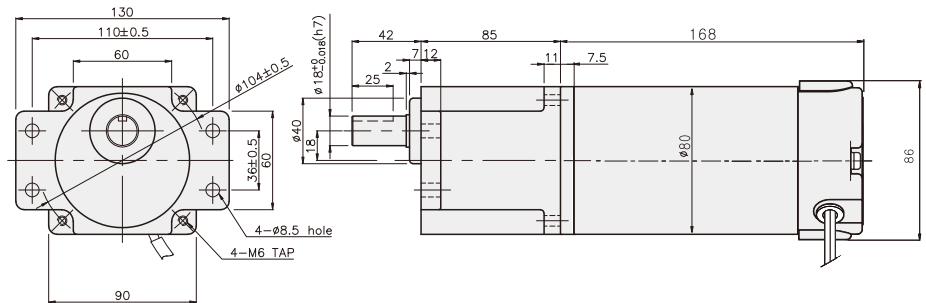

DIMENSION TABLE

PART No	Application Model	Mounting BOLT
01	K9P3~200BU	M6 P1,0 X 20
02	K9P10BX	M6 P1,0 X 65

WEIGHT

PART	WEIGHT(kg)
K9D□150N1	3.50
K9D□150N2	3.20
K9D□200N1	3.70
K9D□200N2	3.40
K9P10BX	0.62
K9P3~10BU	1.44
K9P12,5~20BU	1.55
K9P25~60BU	1.69
K9P75~200BU	1.74

K9DP□N□ + K9P□BU

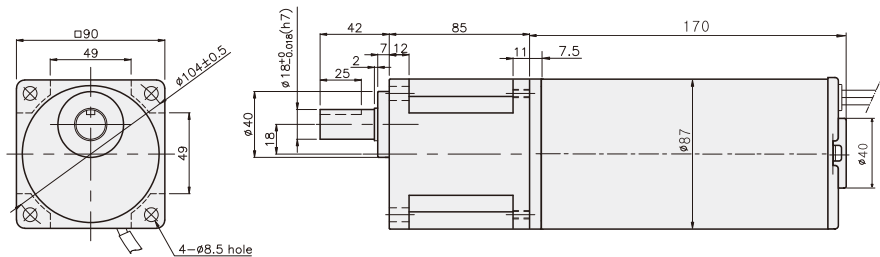

DIMENSION TABLE

PART No	Application Model	Mounting BOLT
01	K9P3~200BUF	M6 P1,0 X 20
02	K9P10BX	M6 P1,0 X 65

WEIGHT

PART	WEIGHT(kg)
K9D□150N1	3.50
K9D□150N2	3.20
K9D□200N1	3.70
K9D□200N2	3.40
K9P10BX	0.62
K9P3~10BUF	1.50
K9P12,5~20BUF	1.62
K9P25~60BUF	1.76
K9P75~200BUF	1.82

K9DP□N□ + K9P□BUF

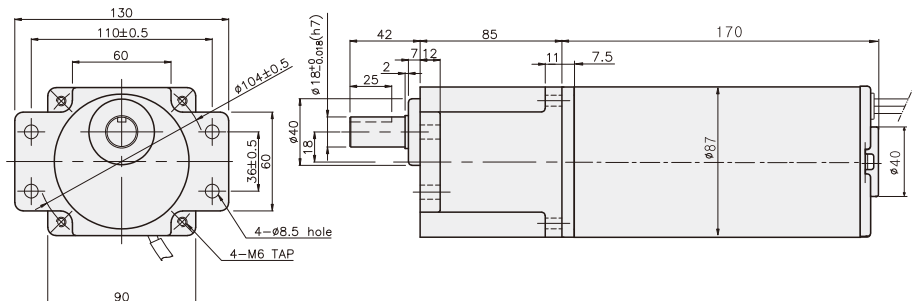

## DC MOTOR

### RATED TORQUE OF GEARHEAD

#### ● K9P□B, K9P□BF

unit = above : N·m / below : Kgf·cm

Model	Speed (rpm)	1000	833	600	500	400	333	300	240	200	167	150	120	100	83	75	60	50	40	33	30	25	20	17	15
		Ratio	3	3,6	5	6	7,5	9	10	12,5	15	18	20	25	30	36	40	50	60	75	90	100	120	150	180
K9DP60N□	0,47 4,7	0,57 5,7	0,79 7,9	0,95 9,5	1,18 11,8	1,42 14,2	1,58 15,8	1,77 17,7	2,13 21,3	2,55 25,5	2,84 28,4	3,19 31,9	3,83 38,3	4,60 46,0	5,11 51,1	6,39 63,9	7,66 76,6	8,62 86,2	10,35 103,5	11,50 115,0	13,80 138,0	17,25 172,5	20 200	20 200	
K9DP90N□	0,71 7,1	0,85 8,5	1,18 11,8	1,42 14,2	1,77 17,7	2,13 21,3	2,37 23,7	2,66 26,6	3,19 31,9	3,83 38,3	4,26 42,6	4,79 47,9	5,75 57,5	6,90 69,0	7,67 76,7	9,58 95,8	11,50 115,0	12,94 129,4	15,52 155,2	17,25 172,5	20 200	20 200	20 200	20 200	

#### ● K9P□BU, K9P□BUF

unit = above : N·m / below : Kgf·cm

Model	Speed (rpm)	1000	833	600	500	400	333	300	240	200	167	150	120	100	83	75	60	50	40	33	30	25	20	17	15
		Ratio	3	3,6	5	6	7,5	9	10	12,5	15	18	20	25	30	36	40	50	60	75	90	100	120	150	180
K9DP90N□	0,71 7,1	0,85 8,5	1,18 11,8	1,42 14,2	1,77 17,7	2,13 21,3	2,37 23,7	2,66 26,6	3,19 31,9	3,83 38,3	4,26 42,6	4,79 47,9	5,75 57,5	6,90 69,0	7,67 76,7	9,58 95,8	11,50 115,0	12,94 129,4	15,52 155,2	17,25 172,5	20,70 207,0	25,87 258,7	30 300	30 300	
K9DP120N□	0,95 9,5	1,14 11,4	1,58 15,8	1,89 18,9	2,37 23,7	2,84 28,4	3,15 31,5	3,55 35,5	4,26 42,6	5,11 51,1	5,68 56,8	6,39 63,9	7,67 76,7	9,20 92,0	10,22 102,2	12,78 127,8	15,33 153,3	17,25 172,5	20,70 207,0	23,00 230,0	27,60 276,0	30 300	30 300	30 300	
K9DP150N□	1,18 11,8	1,42 14,2	1,97 19,7	2,37 23,7	2,96 29,6	3,55 35,5	3,94 39,4	4,44 44,4	5,32 53,2	6,39 63,9	7,10 71,0	7,99 79,9	9,58 95,8	11,50 115,0	12,78 127,8	15,97 159,7	19,17 191,7	21,56 215,6	25,88 258,8	28,75 287,5	30 300	30 300	30 300	30 300	
K9DP200N□	1,58 15,8	1,89 18,9	2,63 26,3	3,15 31,5	3,94 39,4	4,73 47,3	5,26 52,6	5,91 59,1	7,10 71,0	8,52 85,2	9,46 94,6	10,65 106,5	12,78 127,8	15,33 153,3	17,03 170,3	21,29 212,9	25,55 255,5	28,75 287,5	30 300	30 300	30 300	30 300	30 300	30 300	

\* Gearhead and decimal gearhead are sold separately.

\* The code in □ of gearhead model is for gear ratio.

\*   color indicates that the output shaft of the geared motor rotates in the same direction as the output shaft of the motor. Others indicate rotation in the opposite direction.

\* If you are to have less ratio than the ratio in the table, you can install the decimal gearhead, which has one tenth of the ratio, between the gearhead and the motor.